



M H A

2

Matamataig Heinemann Alba

Cumadh, Tomhas agus Làimhseachad Dàta

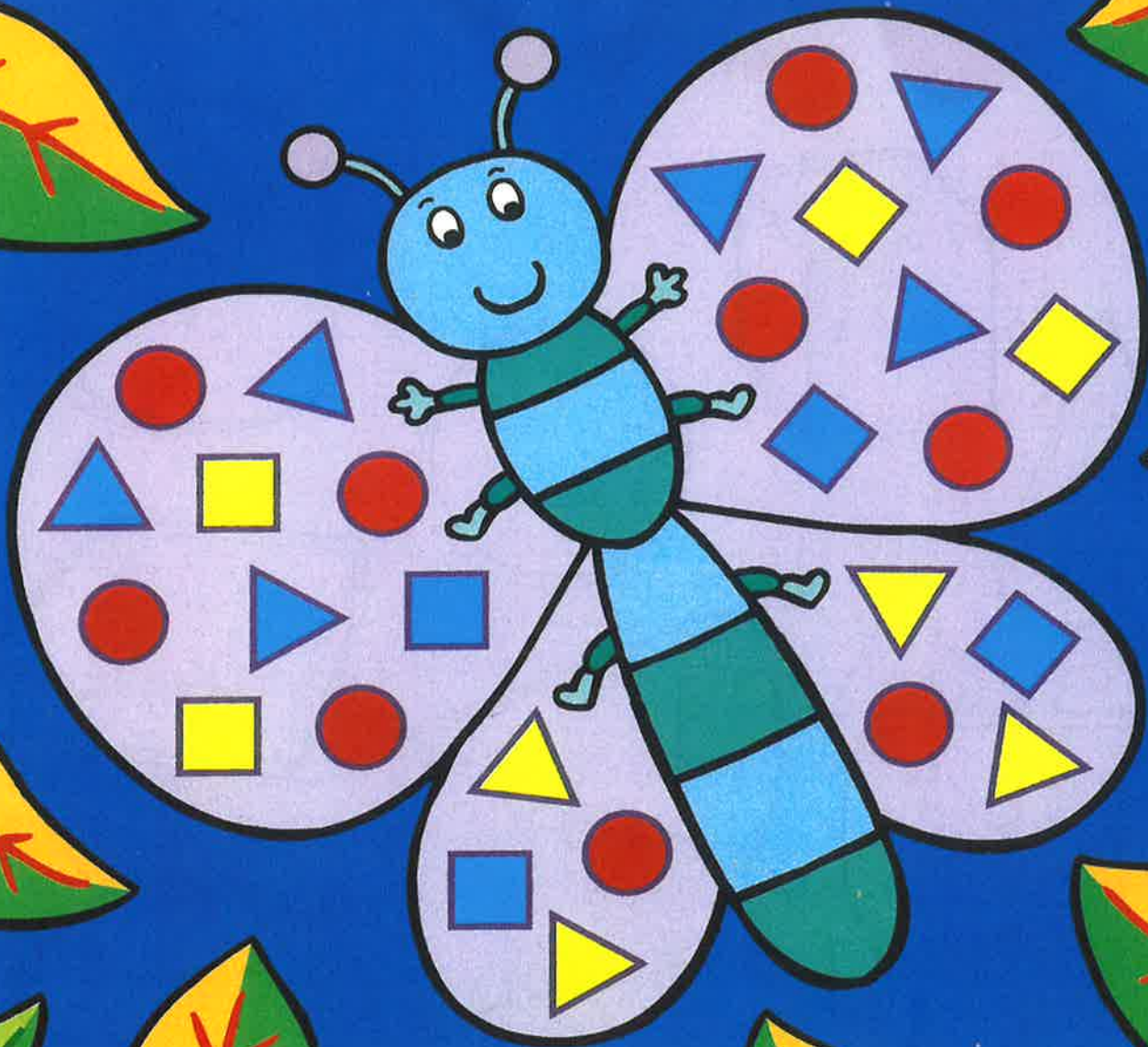

Ainm _____



Cuir dath.

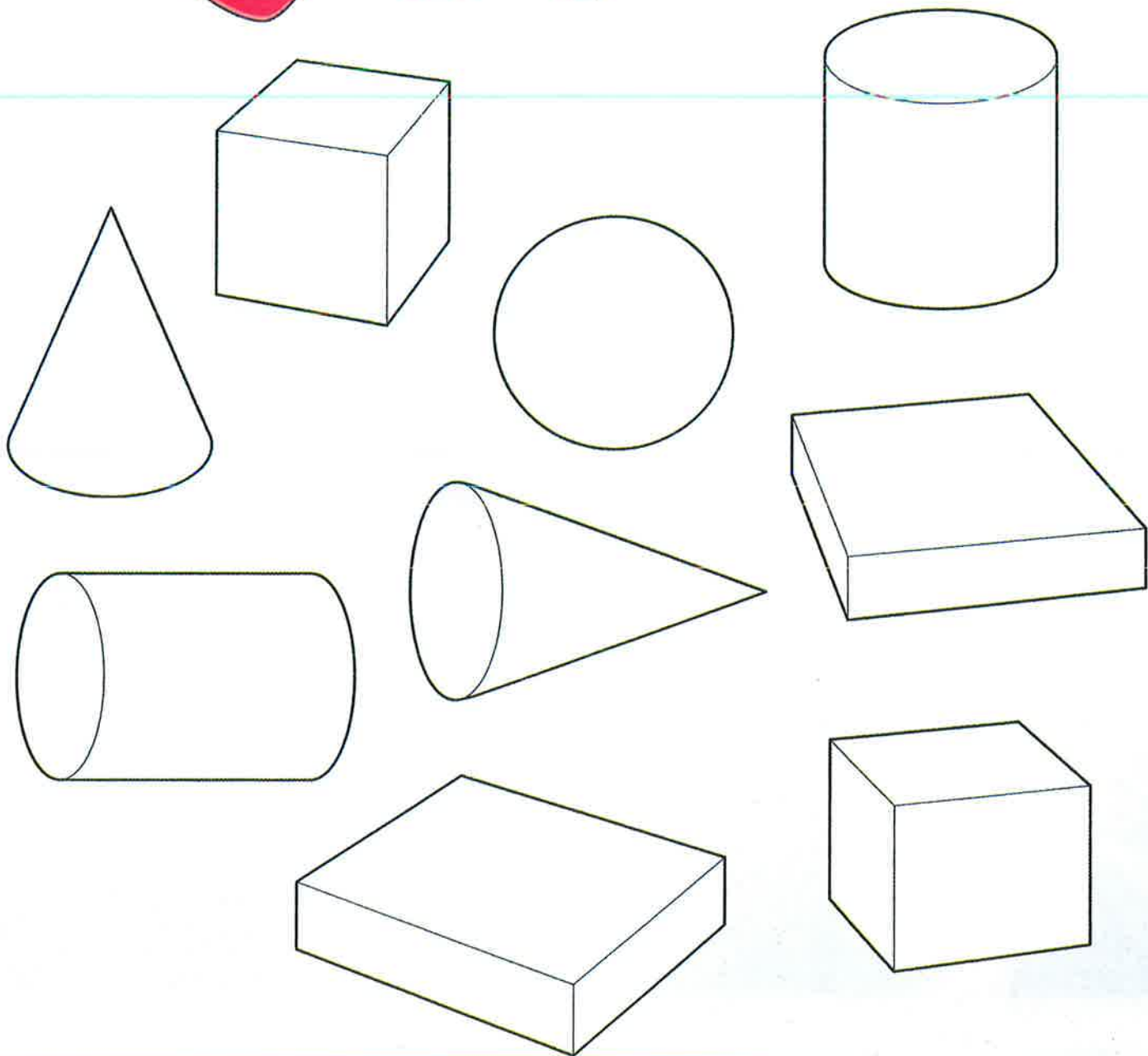
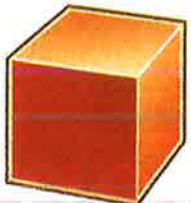

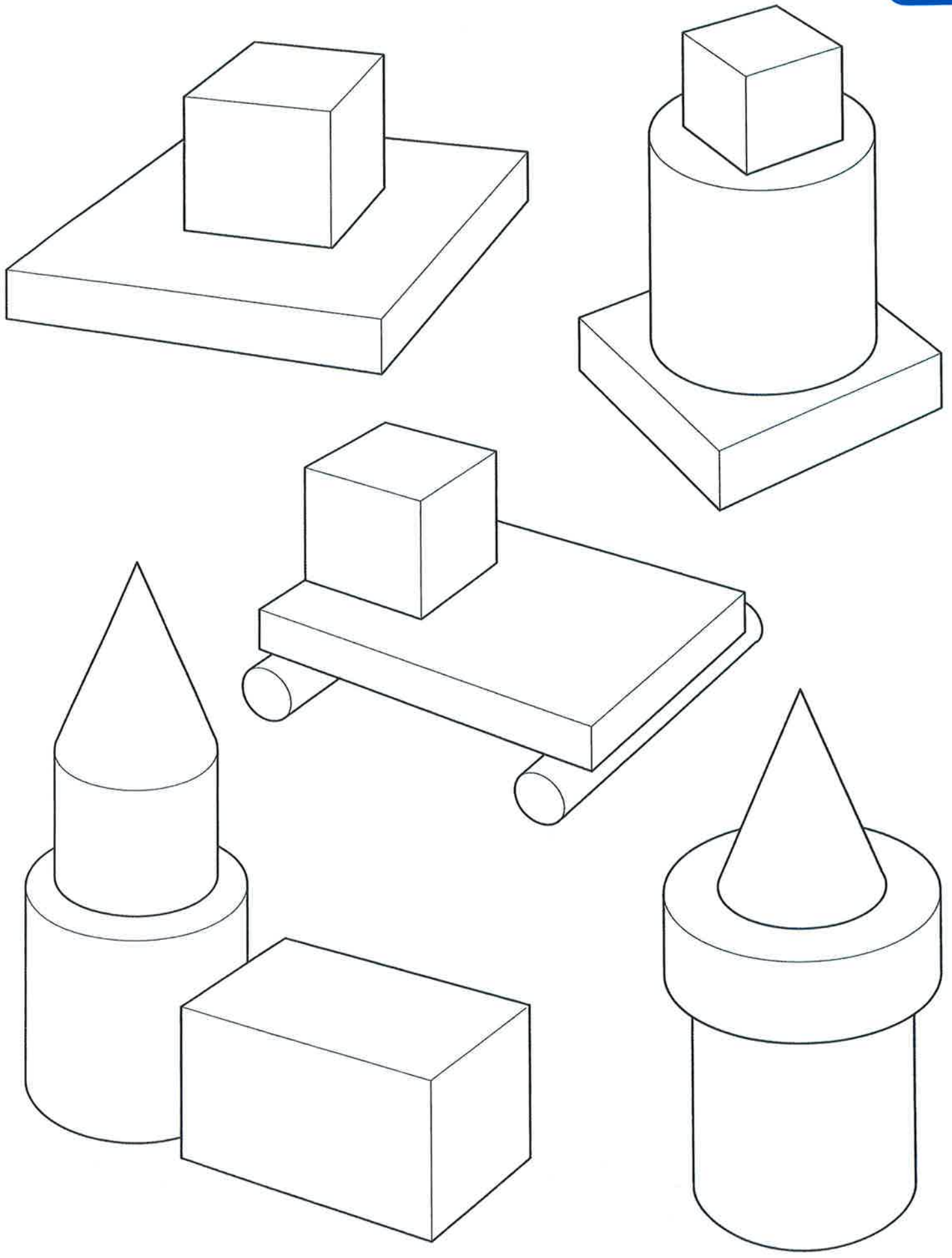

Cuir dath.



ceàrnag

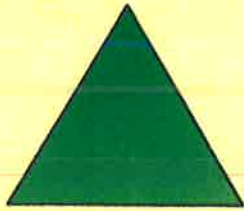

triantan

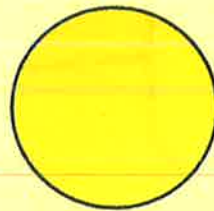

cearcall



ceart-cheàrnach

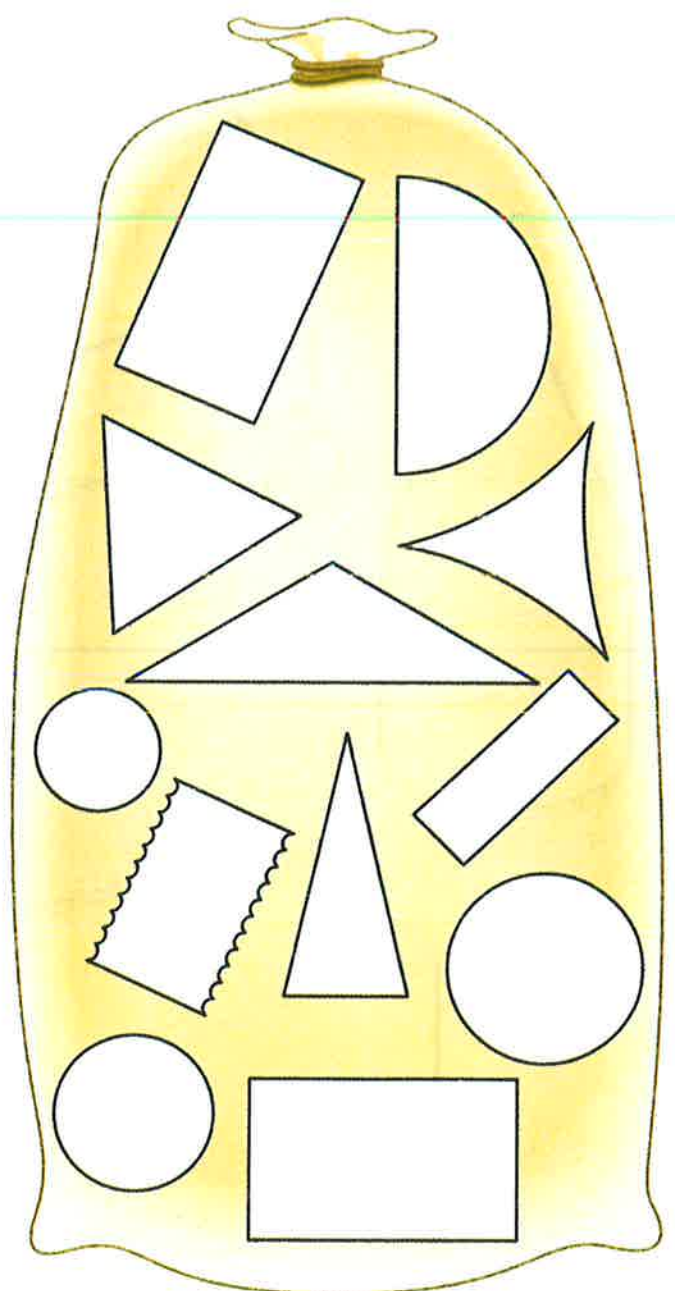
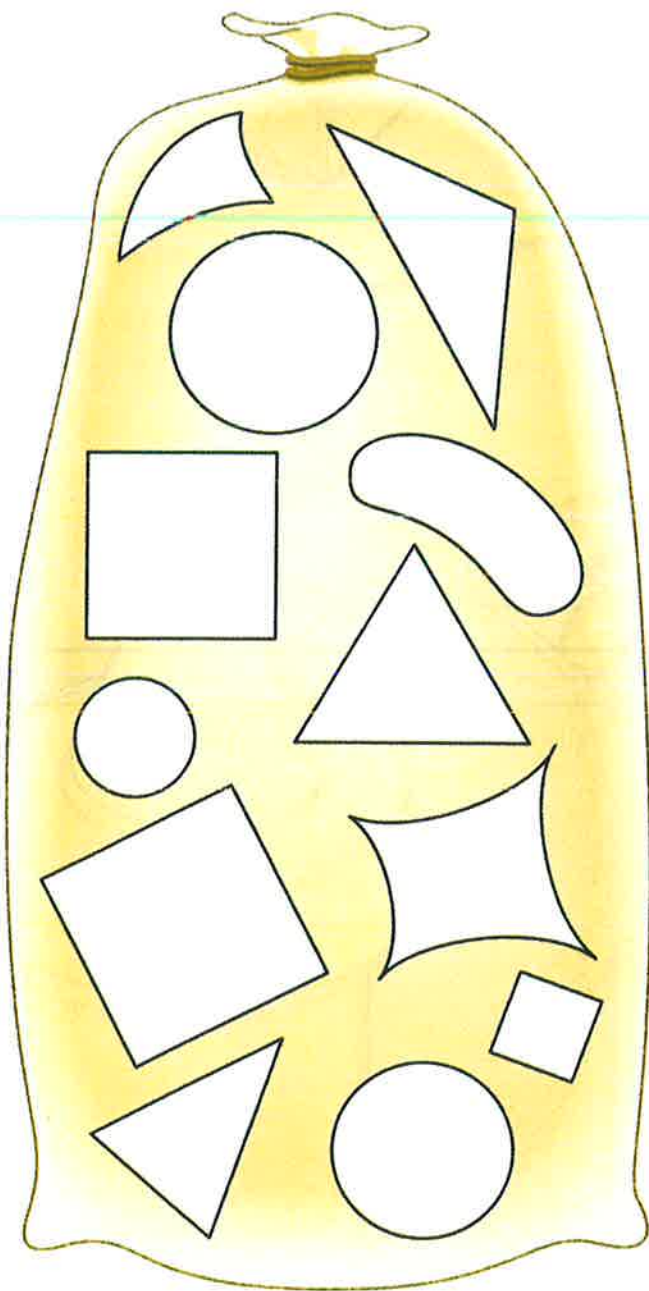

Maid.



cearcall ●

ceàrnag ■

ceart-cheàrnach ▢

triantan ▲



Cia mheud taobh?

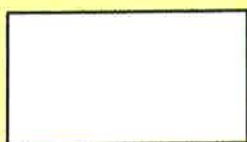

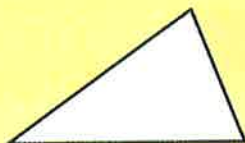



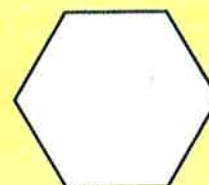

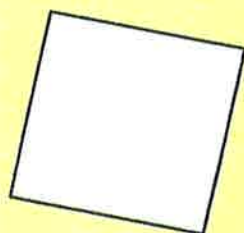



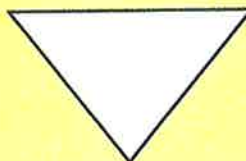



Cuir dath ■ air na ceàrnagan.

Cuir dath ▲ air na triantain.

Cuir dath.

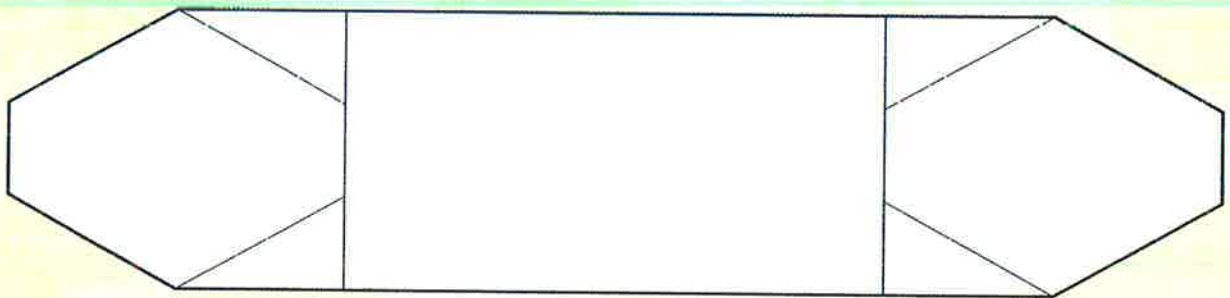
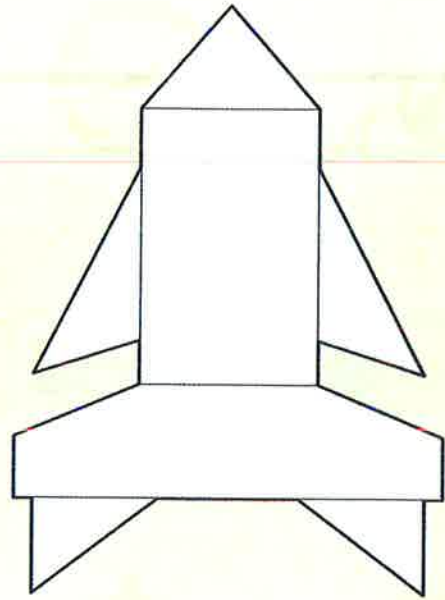
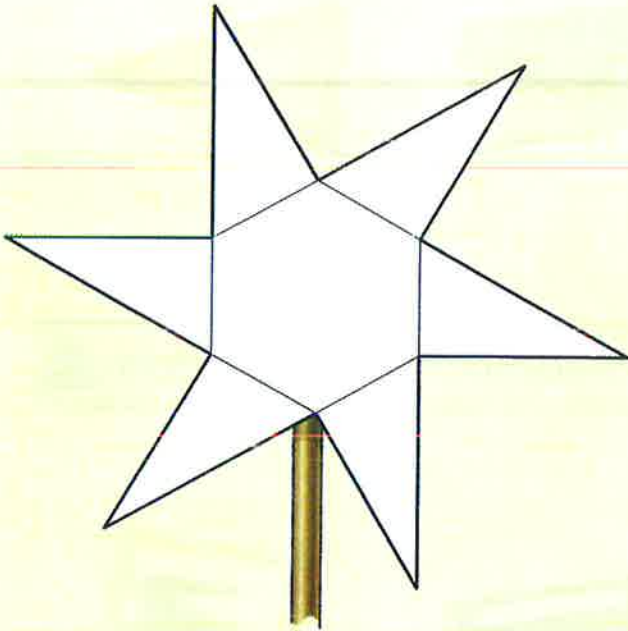

Cia mheud?



—



—



—

Ceangail na spotan. Cuir dath air an .

3 •

• 2

6 • ————— • |

5 •

• 2

4 • ————— • |

4 •

• 3

Cuir crìoch.

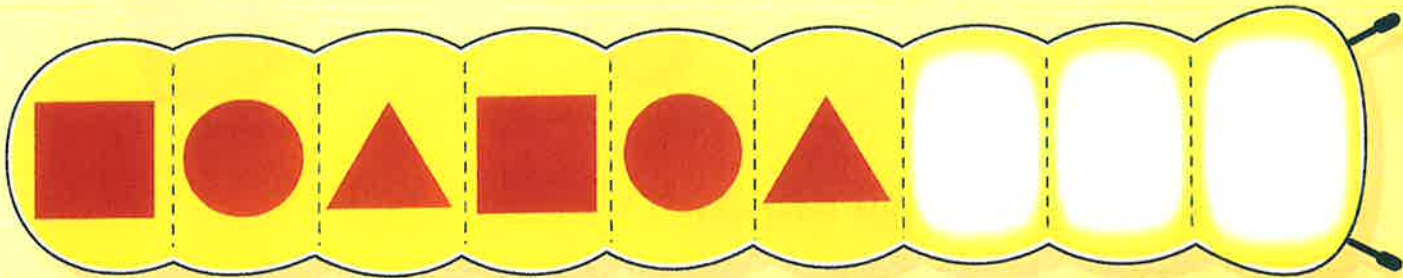
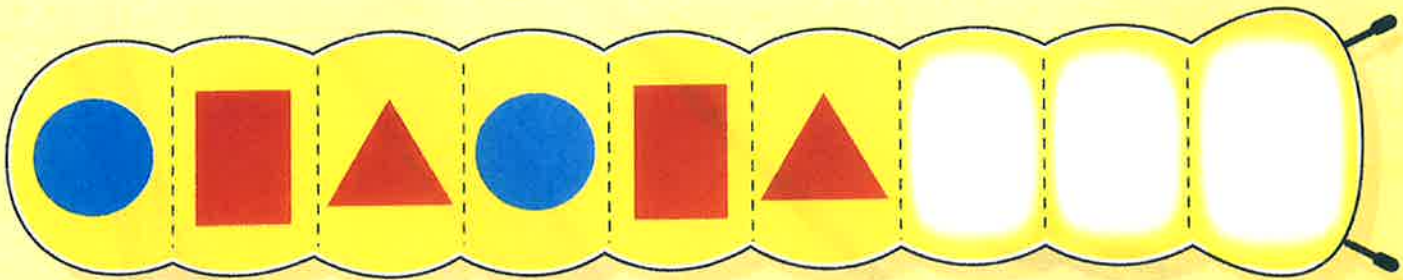
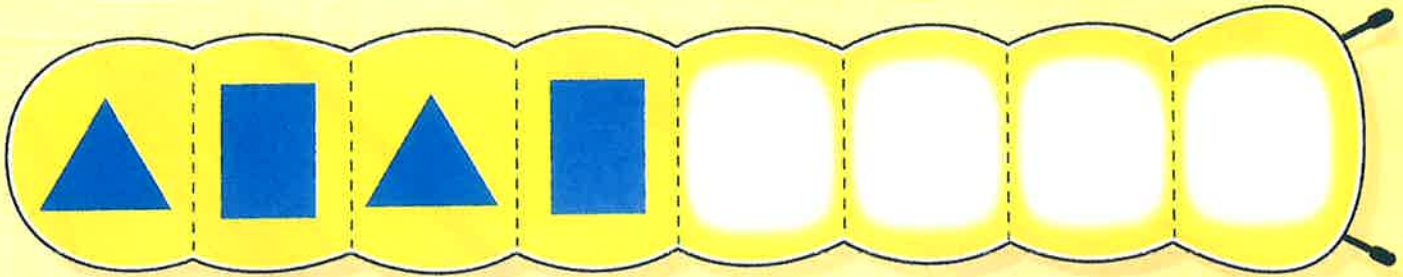
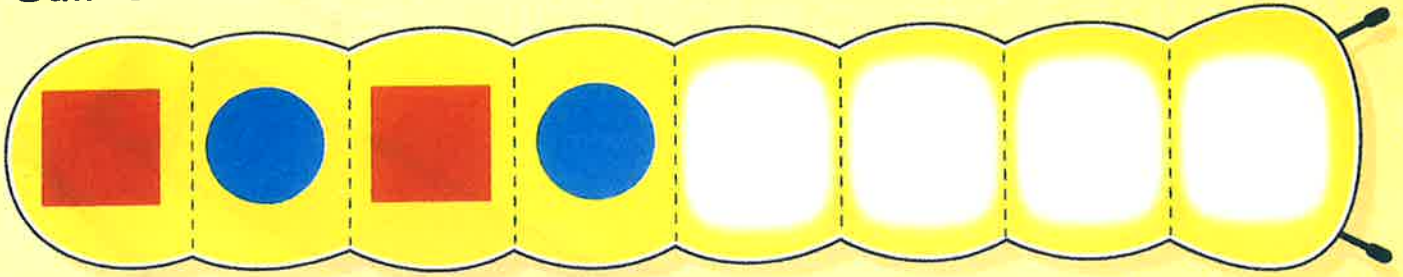

Dèan pàtran.

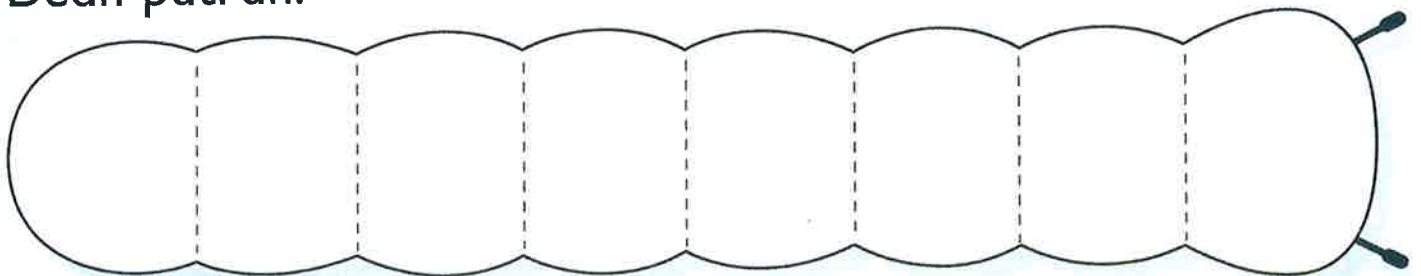

Cuir ✓ air rudan a tha nas fhaide na do

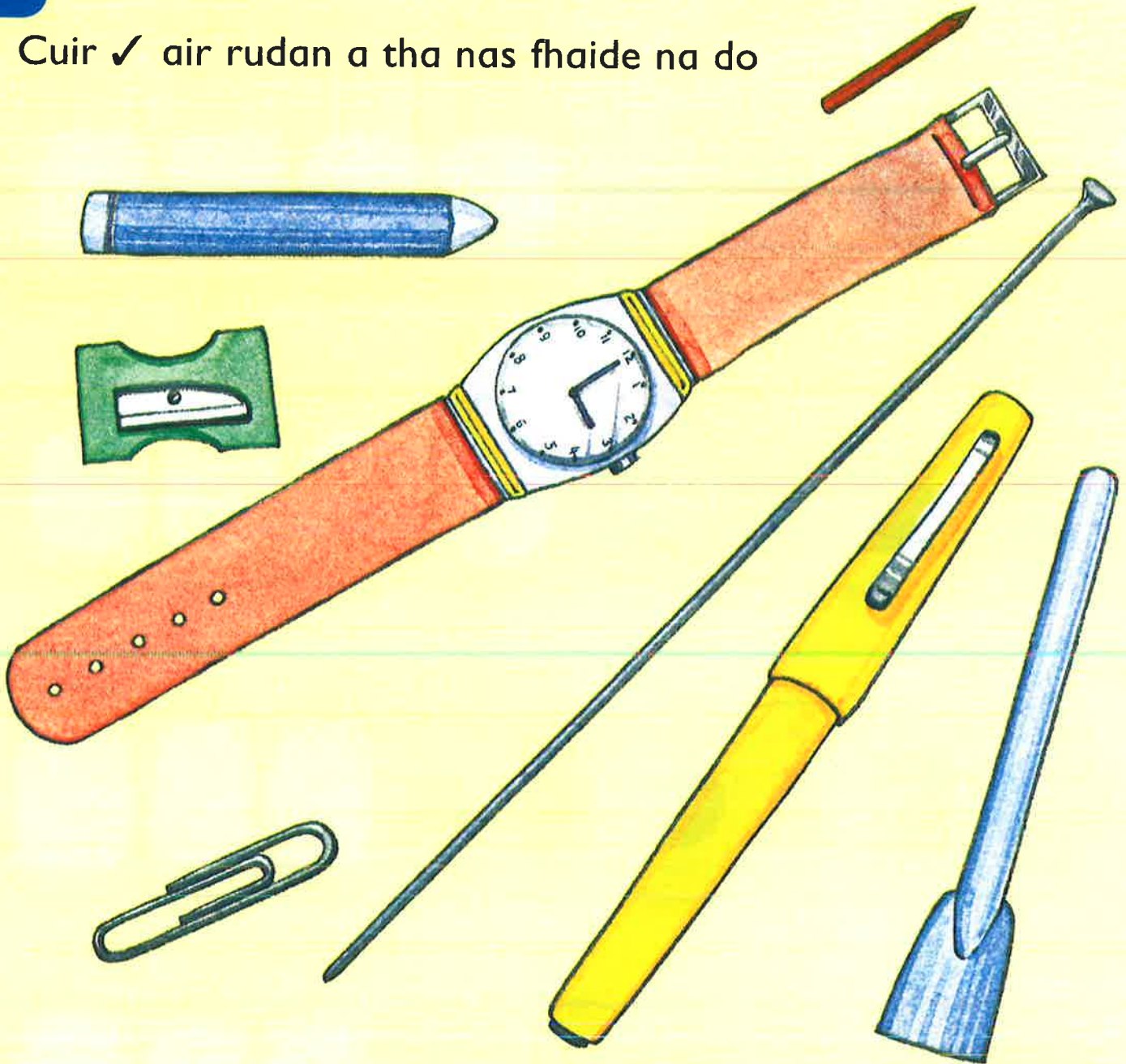

Dèan dealbh de shràbh nas giorra?



Dèan dealbh de chreidhean nas fhaide?



Cuir ✓ air an fhear
as àirde

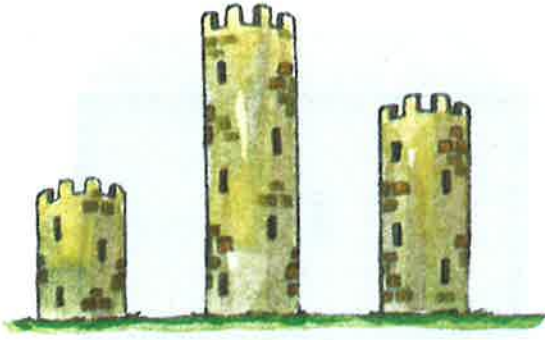

as giorra

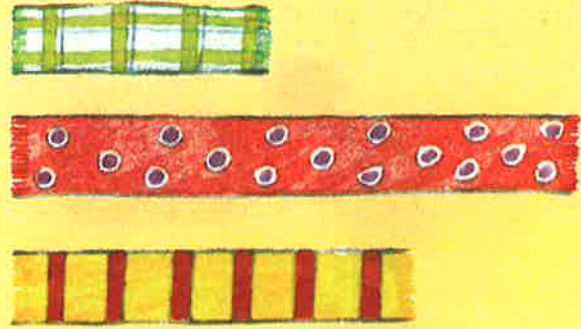

Dèan dealbh de bhalach
nas giorra na Anna.

Dèan dealbh de nighean
nas àirde na Anna.



Cò as àirde sa chlas agad?
Dèan rannsachadh.

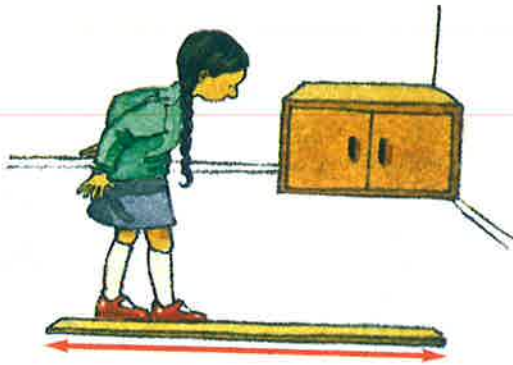
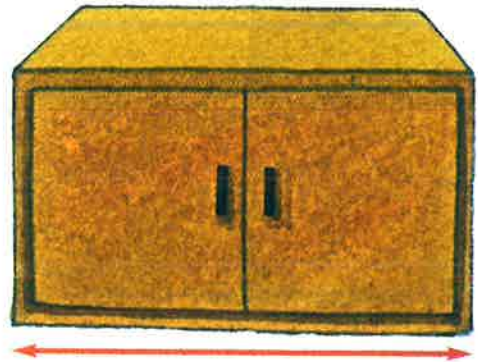
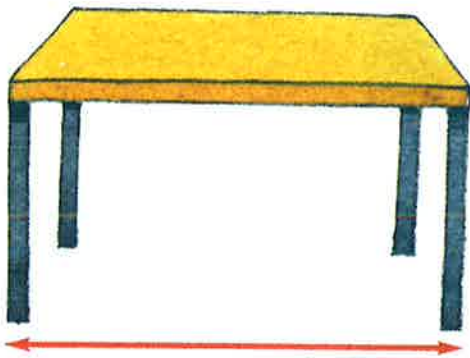

Tomhais le do

mu ceumannanmu ceumannanmu ceumannanmu ceumannan

Cuir ✓ air an fhear as fhaide.

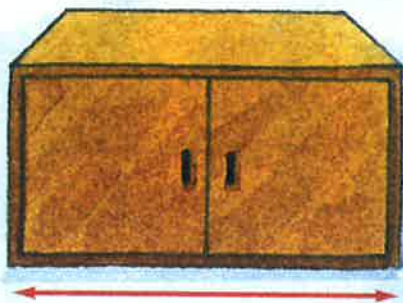

no

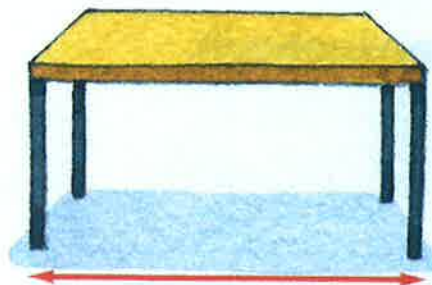

Tomhais le do

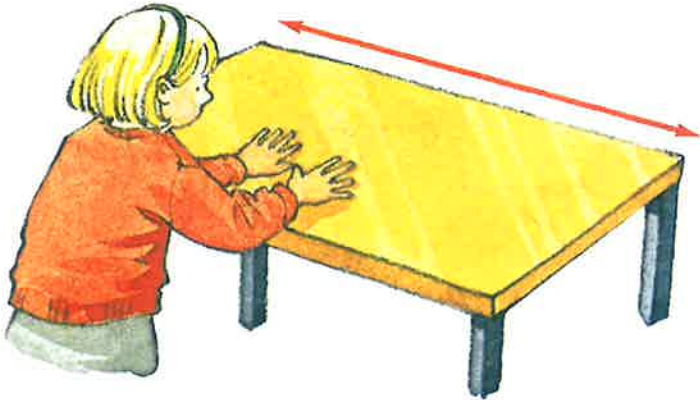

mu rèisean

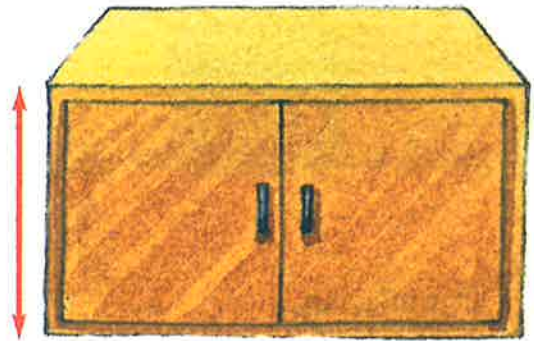

mu rèisean

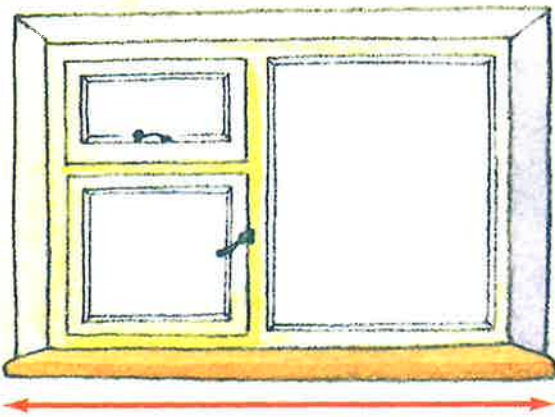

mu rèisean

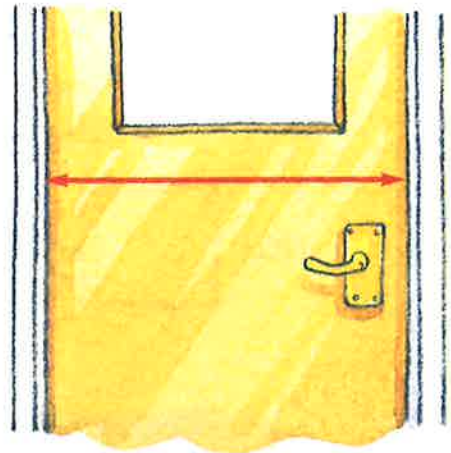

mu rèisean

Cuir ✓ air an fhear as giorra.



no

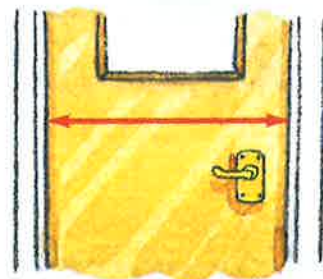

Dè cho fada?

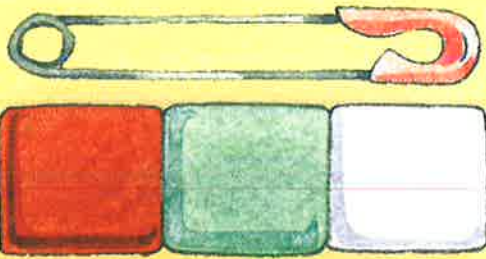

mu ciùban

Tomhais.



mu ciùban



mu chiùb

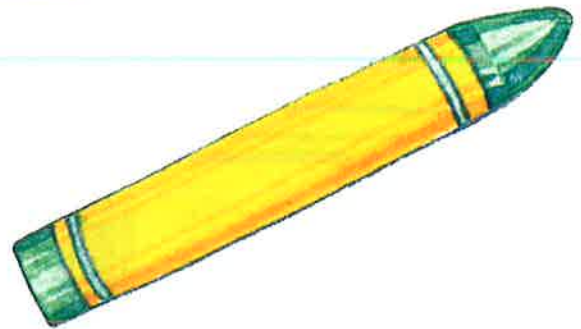

mu ciùban



mu ciùban



mu ciùban

Cuir ✓ air an fhear as fhaide.

Tomhais le sràbhan.

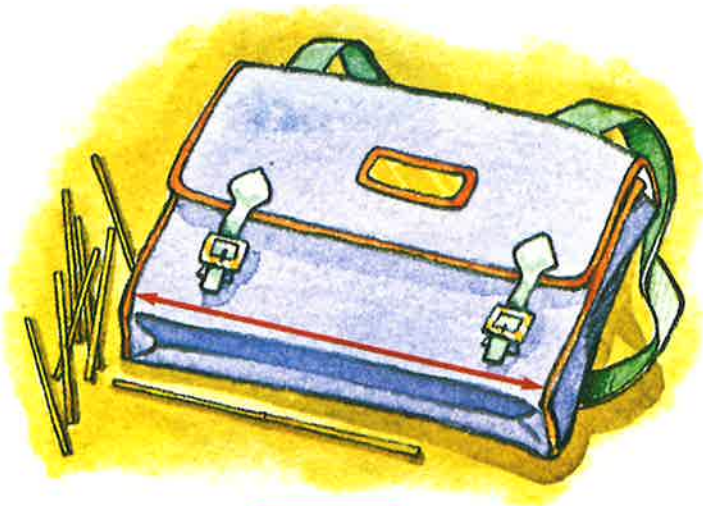

mu shràbh



mu sràbhan



mu sràbhan

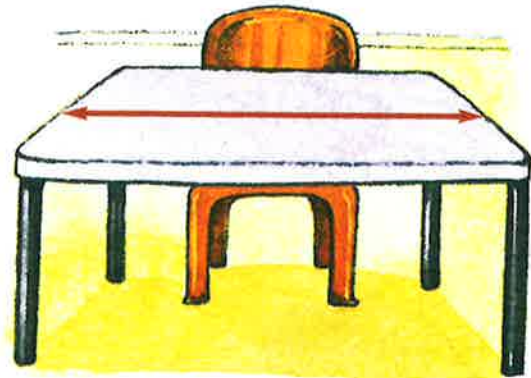

mu sràbhan

Cuir ✓ air an rud as giorra.

Dè chleachdadh tu airson tomhais?

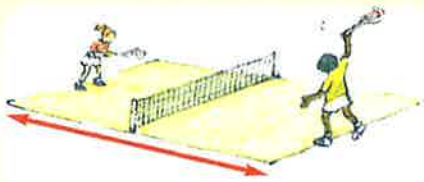
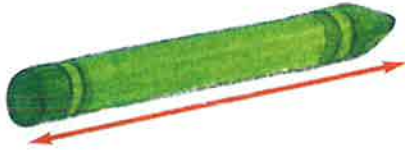

ciùban



sràbhan



maidean



Tuairmse _____ ciùban

Tomhas _____ ciùban



Tuairmse _____ sràbhan

Tomhas _____ sràbhan

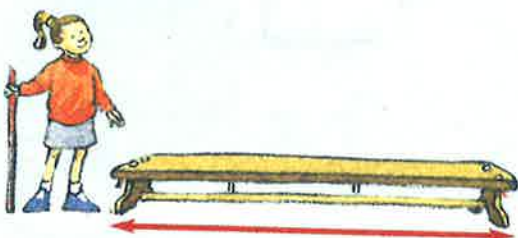

Tuairmse _____ maidean

Tomhas _____ maidean

Cuir ✓ air an rud
as truime

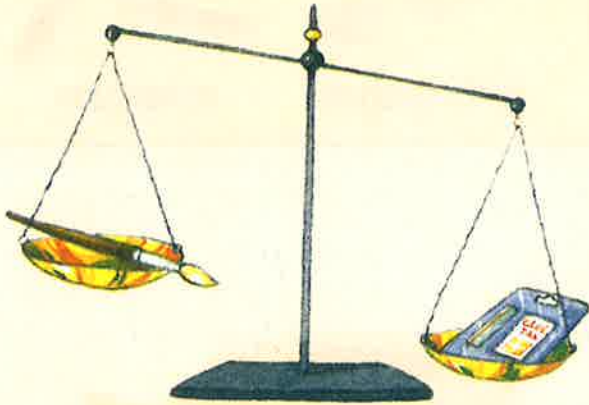

as aotruime

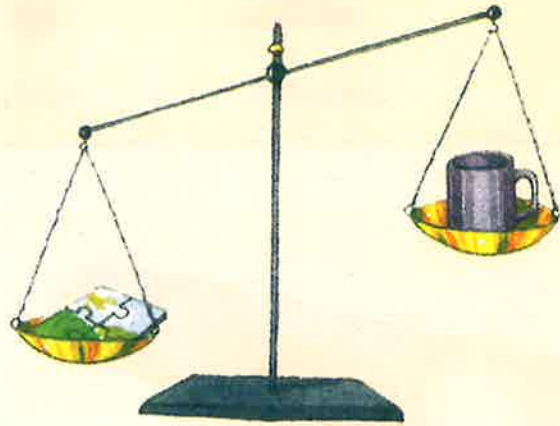

Cleachd  .

Cuir ✓ air an rud as truime.



no



no



Cuir ✓ air an rud as aotruime.



no



no



Cleachd.



meidh

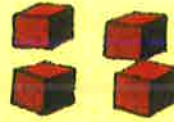

ciùban

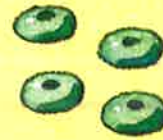

grìogagan



cnagan

Tomhais.



ciùban

grìogagan

cnagan

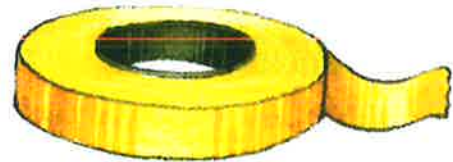

ciùban

grìogagan

cnagan



ciùban

grìogagan

cnagan



ciùban

grìogagan

cnagan

Cleachd



meidh

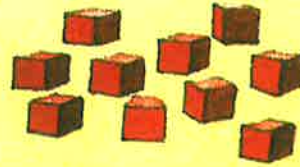

ciùban

Tomhais.



___ ciùban

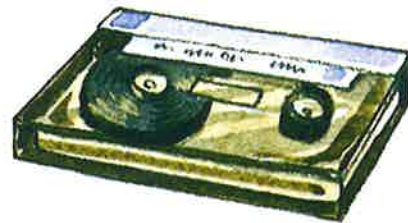

___ ciùban

Cuir ✓ air an rud as truime.

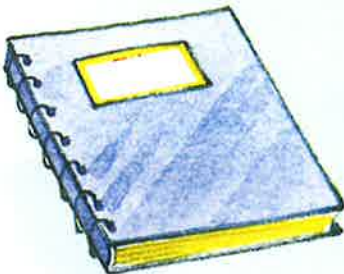

___ ciùban



___ ciùban

Cuir ✓ air an rud as aotruime.

Dèan dealbh de rud sa bheil mu 10 ciùban de chuideam.



Cuir ✓ air an rud as motha a ghabhas de dh'uisge.



Cuir ✓ air an rud as motha a ghabhas de dh'uisge.



Cia mheud  ?



mu

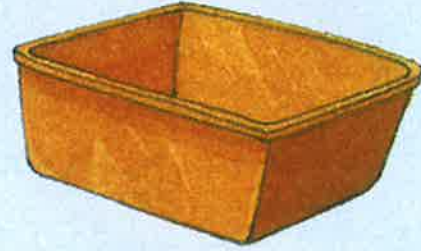

mu

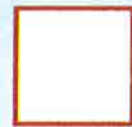

mu



mu



Cuir ✓ air an rud as lugha a ghabhas de dh'uisge.



no



Cleachd  no .



mu

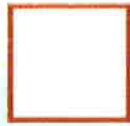

mu



mu



mu

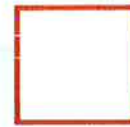

Cuir ✓ air an rud as motha a ghabhas de dh'uisge.





8 cupannan



6 cupannan



3 cupannan

Cia mheud cupa gu lèir?



cupannan



cupannan



cupannan



cupannan

Cia mheud cupa a bharrachd a ghabhas an  ?

a bharrachd



a bharrachd

Cleachd cunntairean beaga .

Cia mheud cunntair a dh'fheumas tu airson gach làrach a chòmhdach?



mu _____ cunntairean



mu _____ cunntairean

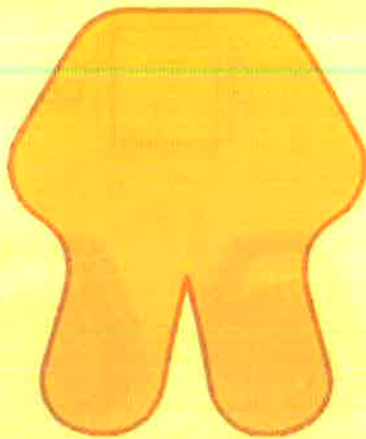

mu _____ cunntairean

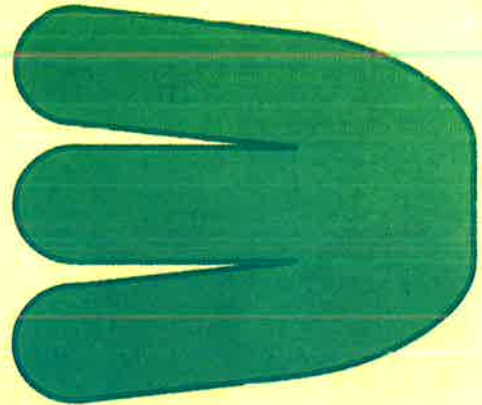

mu _____ cunntairean

Dè an làrach a tha a' còmhdach

- an fharsaingeachd as motha? _____
- an fharsaingeachd as lugha? _____



Cia mheud cunntair a dh'fheumas tu airson làrach do làimh a chòmhdach?

mu _____ cunntairean

Sgrìobh farsaingeachd gach cumadh.

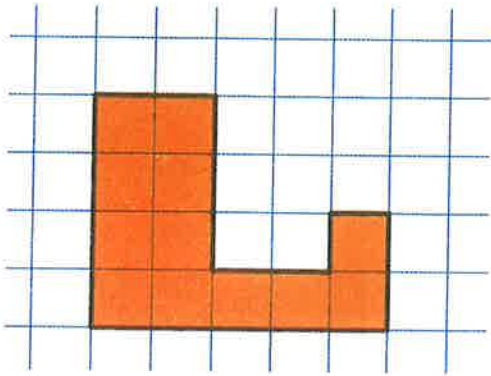

_____ ceàrnagan

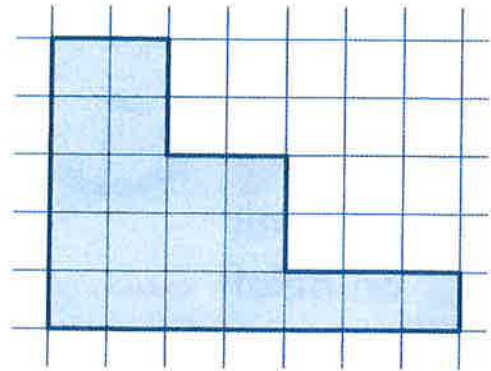

_____ ceàrnagan

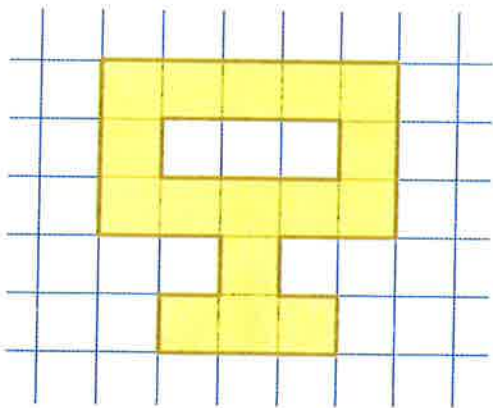

_____ ceàrnagan

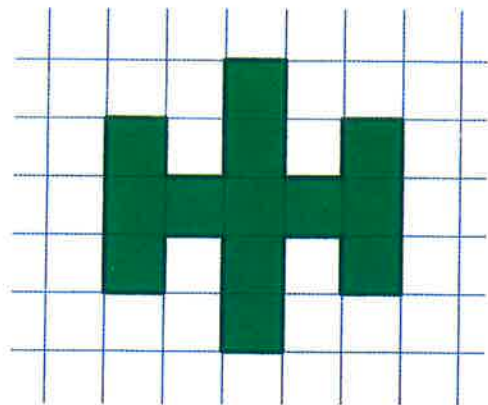

_____ ceàrnagan

Cuir ✓ air a' chumadh leis an fharsaingeachd as motha.

Cuir ✗ air a' chumadh leis an fharsaingeachd as lugha.

Dèan dealbh agus cuir dath air cumaidhean le farsaingeachd de:

8 ceàrnagan

12 ceàrnagan

20 ceàrnag.

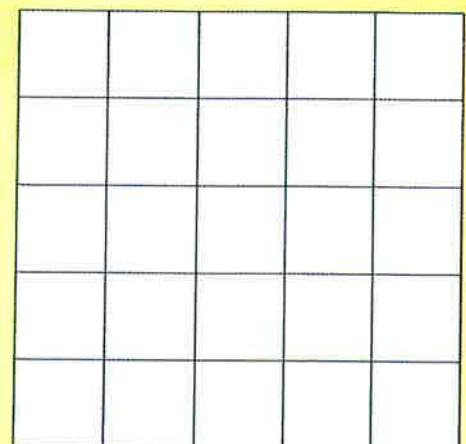
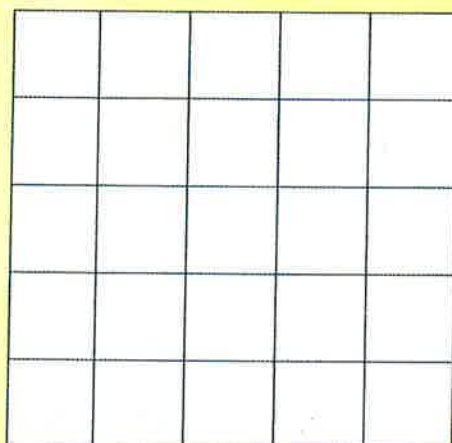
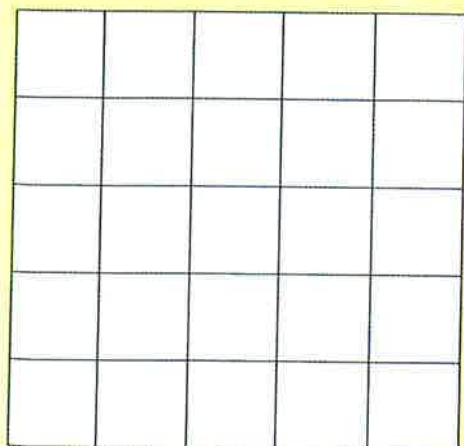

Sgrìobh gach uair.



leth uair
an dèidh _____



leth uair
an dèidh _____

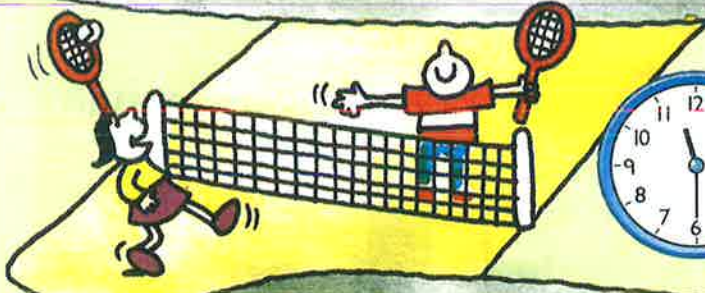

leth uair
an dèidh _____



leth uair
an dèidh _____



leth uair
an dèidh _____



leth uair
an dèidh _____



leth uair
an dèidh _____



leth uair
an dèidh _____

Muids.



leth uair an dèidh 2



uair



leth uair an dèidh 6



leth uair an dèidh 7

aon uair deug



8 uairean



Muids le dathan.

leth uair an dèidh 12



10 uairean



leth uair an dèidh 5



Sgrìobh gach uair.

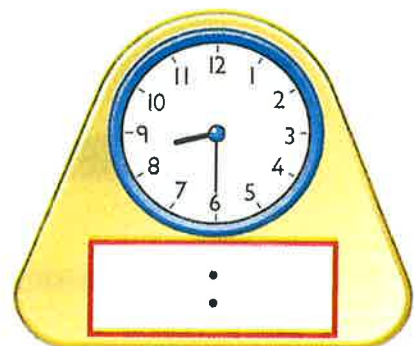
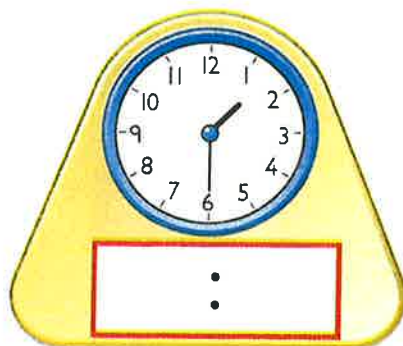

Sgrìobh an uair

uair a thìde an dèidh



uair a thìde ro



2 uair a thìde ro

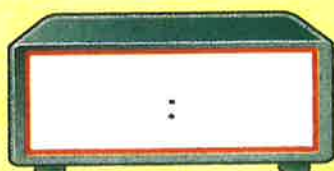

2 uair a thìde an dèidh

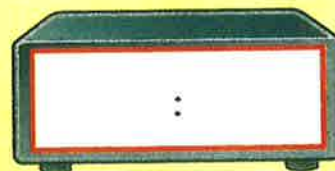

Cuir dath.

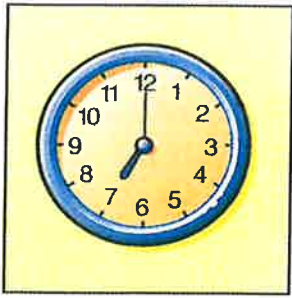

uair a thìde
an dèidh

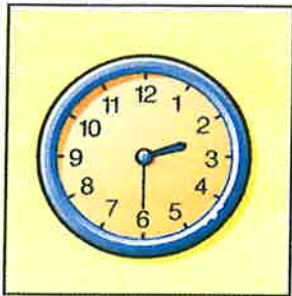
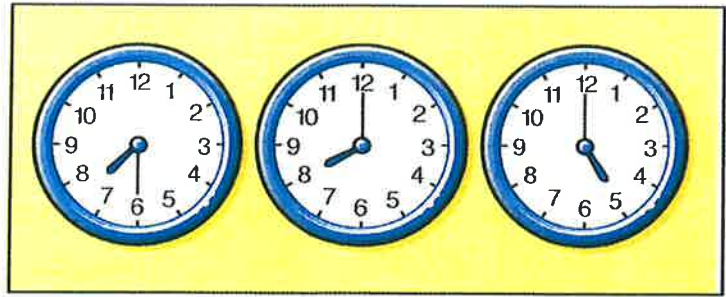

2 uair a thìde
an dèidh

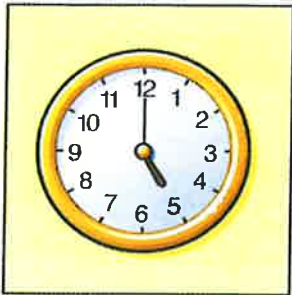
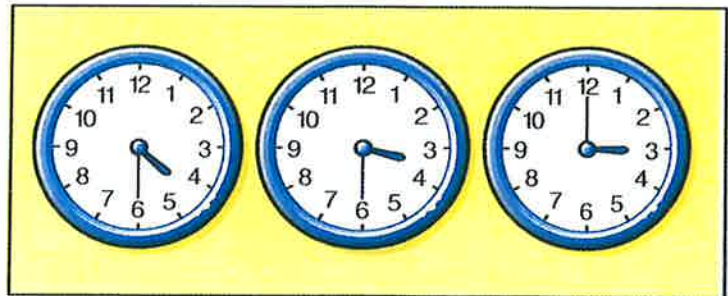

uair a thìde
ro

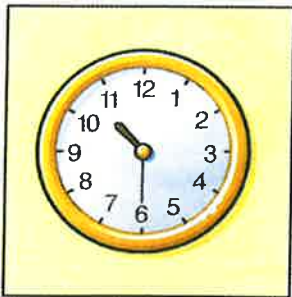
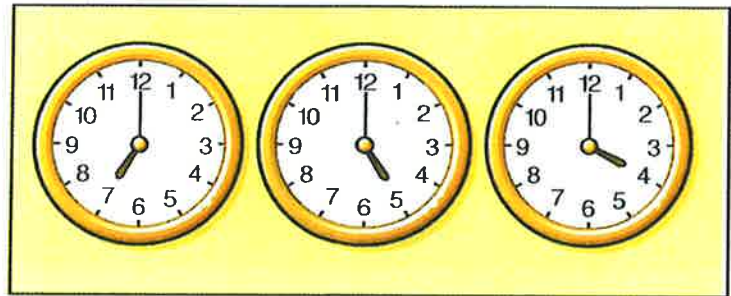

2 uair a thìde
ro

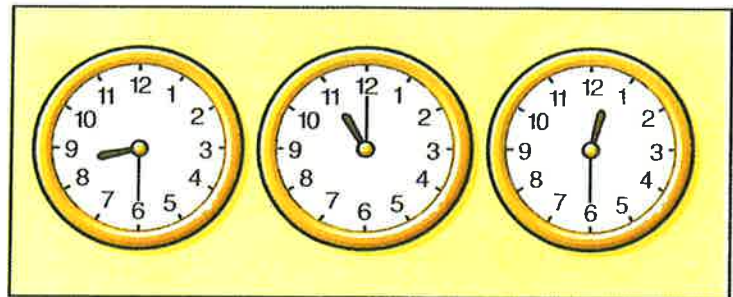

3 uairean a thìde ro



uairean



3 uairean a thìde
an dèidh

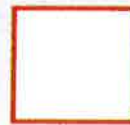

uairean

toiseach

crìoch

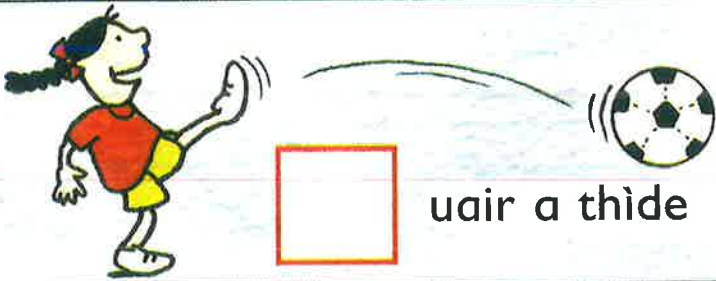
5:00  6:00

uair a thìde

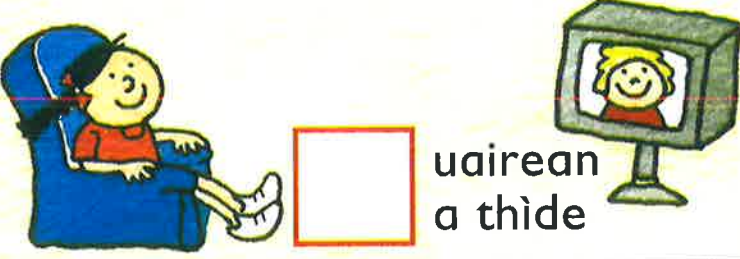
7:30  10:30

uairean a thìde

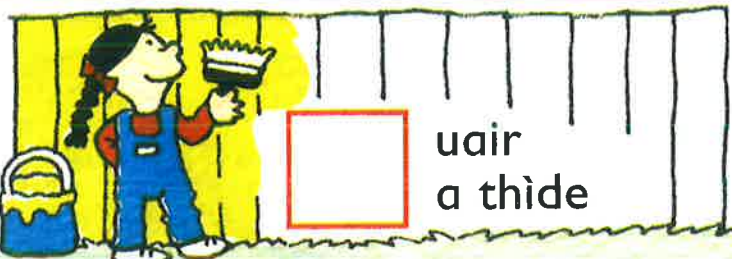
10:30  12:30

uair a thìde

 uairean  uairean a thìde  uair dheug

 leth uair an dèidh  uair a thìde  leth uair an dèidh

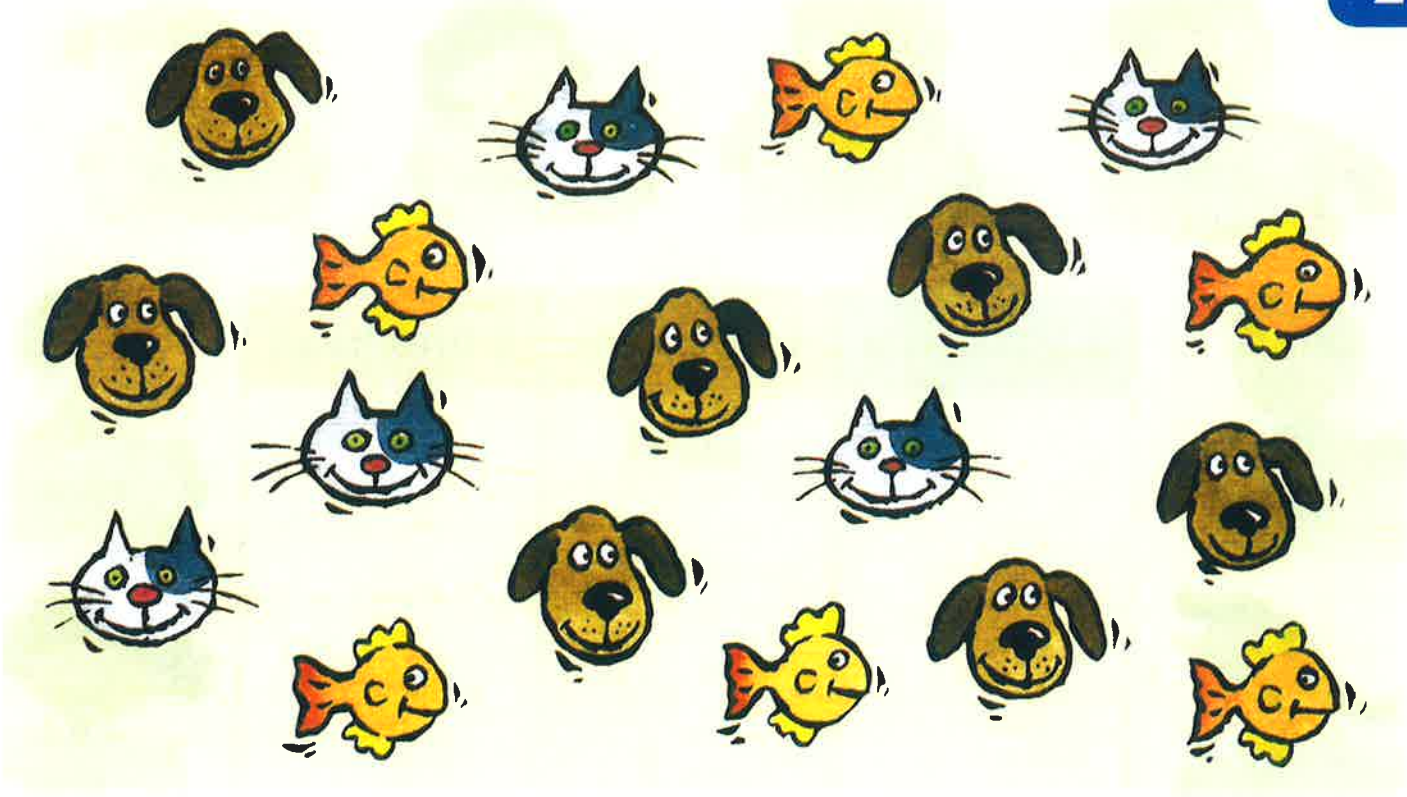

Cia mhead?







Peataichean



--	--	--	--	--	--	--	--	--



--	--	--	--	--	--	--	--	--



--	--	--	--	--	--	--	--	--

Cia mhead  a bharrachd air  ? _____

Cia mhead  a bharrachd air  ? _____



3 litrichean	4 litrichean	5 litrichean
	Iain	



Cuir dath.

Litrichean anns na h-ainmean

Àireamh chloinne

3 litrichean 4 litrichean 5 litrichean



Salma

sa chlàr. Cuir dath air a' ghraf.

Dinnearan



Àireamh chloinne

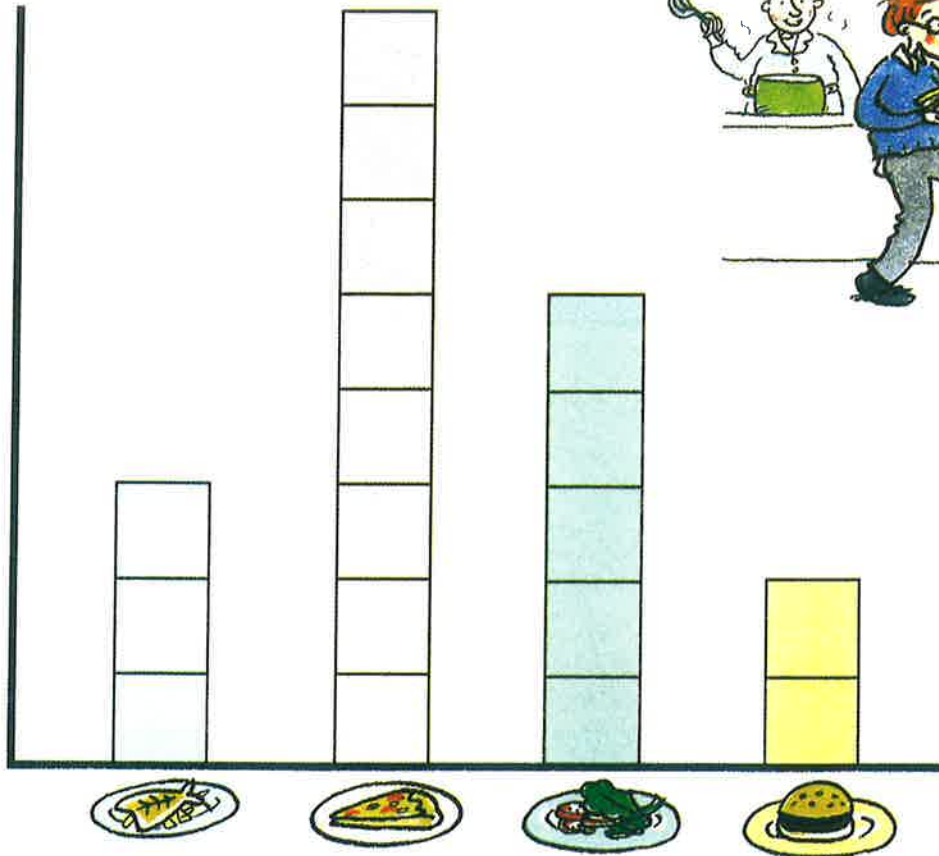

Cia mheud sgoilear a ghabh



Cia mheud sgoilear a ghabh dinneair? _____

Cuir ✓ air an dinneair a ghabh a' chuid as motha.



Cia mheud sgoilear a bharrachd a ghabh



Dèan graf dhinnearan dhen chlas agad.

Cuir na h-àireamhan air na clàran.



cothromach

corra

	31
--	----



Cuir crìoch.

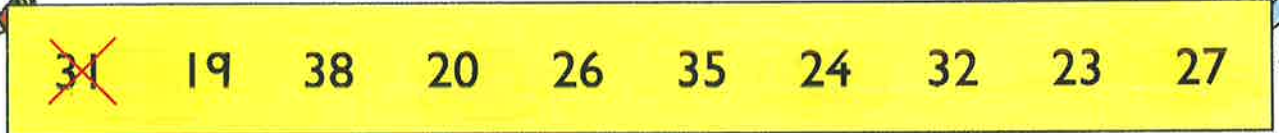

cothromach

corra



àireamhan
nas lugha na 25

àireamhan
nach eil
nas lugha
na 25

	31

A' làimhseachadh dàta: Diagraman Carroll

Foillsichearan Foghlaim Heinemann, Halley Court, Jordan Hill, Oxford OX2 8EJ

© Scottish Primary Mathematics Group

a' chiad fhoillseachadh 2000

A' chiad fhoillseachadh anns a' Ghàidhlig le Stòrlann Nàiseanta na Gàidhlig às leth Riaghaltas na h-Alba.

Air ath-fhoillseachadh ann an 2005, 2012, 2015.

© na Gàidhlig Stòrlann Nàiseanta na Gàidhlig

Na còraichean uile glèidhte. Chan fhaodar pàirt sam bith dhen leabhar seo ath-riochdachadh ann an cruth sam bith gun

chead ro-làmh ann an sgrìobhadh bho Stòrlann Nàiseanta na Gàidhlig.

Tha Stòrlann Nàiseanta na Gàidhlig a' faighinn taic bho Bhòrd na Gàidhlig.